



UNOMAS

Tarım Makineleri

Bereketli toprakların mimarı...

Ürün
Kataloğu
Product
Catalogue

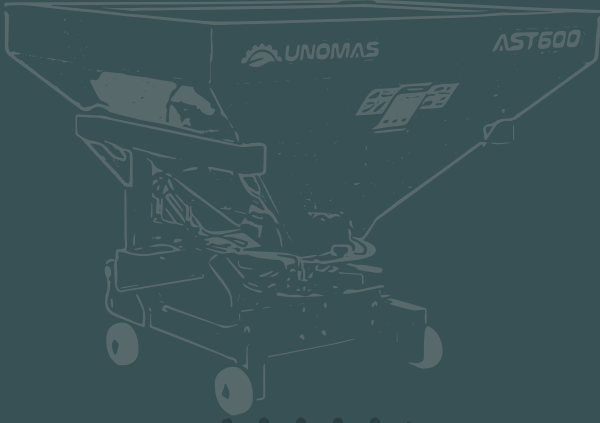

AST SERIES

Tek Diskli Gübre Serpme Makinesi / Single Disc Fertilizer Spreader
Dikey Mil Karıştırıcı / Vertical Mixer
Hidrolik Kontrol Sistemi / Hydraulic Control System
16-20m İş Geniřlięi / 16-20m Working Width

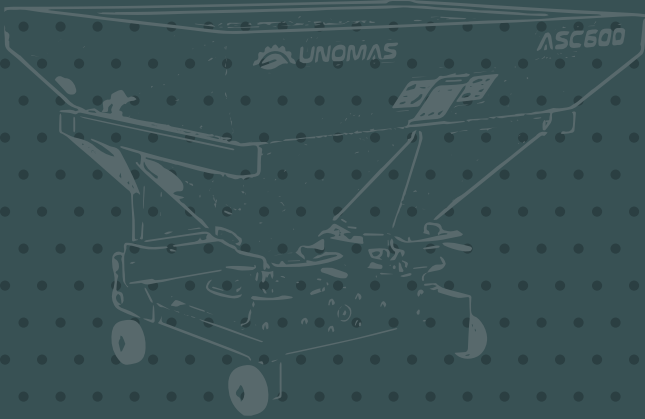

ASC SERIES

Çift Diskli Gübre Serpme Makinesi / Double Disc Fertilizer Spreader
Dikey Mil Karıştırıcı / Vertical Mixer
Hidrolik Kontrol Sistemi / Hydraulic Control System
18-24m İş Geniřlięi / 18-24m Working Width
Şanzıman Arası Mesafe : 50 cm / Transmission Distance : 50 cm



BSC SERIES

Çift Diskli Gübre Serpme Makinesi / Double Disc Fertilizer Spreader
Dikey Mil Karıştırıcı / Vertical Mixer
Hidrolik Kontrol Sistemi / Hydraulic Control System
18-24m İş Geniřlięi / 18-24m Working Width
Şanzıman Arası Mesafe : 50 cm / Transmission Distance : 50 cm
Çevre Koruma Bariyeri / Environmental Protection Barrier



CS
SERIES

Çift Diskli Gübre Serpme Makinesi / Double Disc Fertilizer Spreader
Dikey Mil Karıştırıcı / Vertical Mixer
Hidrolik Vana Kontrol Sistemi / Hydraulic Valve Control System
18-24m İş Geniřliđi / 18-24m Working Width
Şanzıman Arası Mesafe : 65 cm / Transmission Distance : 65 cm
Çevre Koruma Bariyeri / Environmental Protection Barrier
Sekizgen Tasarım / Octagonal Design

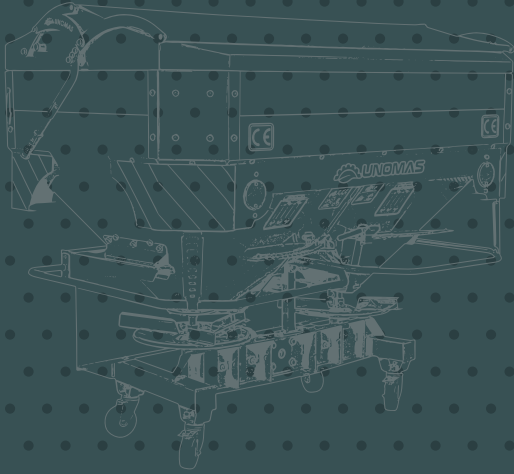

DS
SERIES

Çift Diskli Gübre Serpme Makinesi / Double Disc Fertilizer Spreader
Dikey Mil Karıştırıcı / Vertical Mixer
Hidrolik Vana Kontrol Sistemi / Hydraulic Valve Control System
24-30m İş Geniřliđi / 24-30m Working Width
Şanzıman Arası Mesafe : 80 cm / Transmission Distance : 80 cm
Çevre Koruma Bariyeri / Environmental Protection Barrier
Sekizgen Tasarım / Octagonal Design

daha fazla ürün ve bilgi için;
for more products and information;
www.unomas.com.tr



AST Serisi | Gübre Serpme Makinesi

Asılı tip AST Serisi gübre serpme makinelerimiz 5 farklı kapasite (L) seçeneği ile üretilmektedir. Makinemizde bulunan hidrolik kontrol sistemi ile kolay kullanım imkanı sağlanmakta ve gereksiz gübre sarfiyatının da önüne geçilmektedir. 16-20m iş genişliğine sahip disklerimizin üzerinde bulunan açılabilir kanatlarımız, gübrenin tarlaya daha homojen ve akıcı dağılması için gübre cinsine ve istenilen atım mesafesine göre kolay ayarlanabilmektedir. Makinemizde bulunan sürgülü ayar kolları ile sağ veya sol tarafa ayrı ayrı gübre atımı yapılabilmekte ve gübre atış miktarı hassas bir şekilde ayarlanabilmektedir. Depo içerisinde bulunan elek sayesinde yabancı cisimlerin sisteme zarar vermesi önlenmektedir. Gübrenin toz oluşumunu minimum seviyeye indirecek şekilde tasarlanan dikey karıştırıcı ile gübre akışı kesintisiz olarak sağlanmaktadır. Makinelerimizin yüzey temizliğinde statik boya tekniği öncesi çinko fosfat sistemi uygulanmaktadır. Bu sayede doğal oksitlenmelere karşı metal yüzeylerin ömrü ve mukavemeti artırılmaktadır.

OPSİYONLAR

- Çadır; depodan gübre dökülmesini ve yağışlı havalarda gübrenin ıslanmasını önler.
- Krom disk; gübrenin oluşturabileceği korozyonu önler.



Sürgülü Ayar Kolları
Sliding Adjustment Handles

AST Series | Fertilizer Spreader

Our hanging type fertilizer spreaders are produced with 5 different capacities (L) options. With the hydraulic control system in our machine, easy use is provided and unnecessary fertilizer consumption is prevented. Angle adjustable wings on our discs, with a working between 16-20m can be easily adjusted according to the type of fertilizer and the desired spreading distance in order to distribute the fertilizer more homogeneously and fluently on the field. With the sliding adjustment handles on our machine, fertilizer can be applied separately to the right or left side and the amount of fertilizer can be adjusted precisely. Thanks to the sieve in the tank, foreign objects are prevented from damaging the system. With the vertical mixer, which is designed to minimize the dust formation of the fertilizer, the fertilizer flow is provided uninterruptedly. Zinc phosphate system is applied before the static paint technique in the surface cleaning of our machines. In this way, the life and strength of metal surfaces against natural oxidation are increased.

OPTIONS:

- Tent; it prevents fertilizer spillage from the tank and wetting of the fertilizer in rainy weather.
- Chrome disc; it prevents the corrosion that can be caused by the fertilizer.

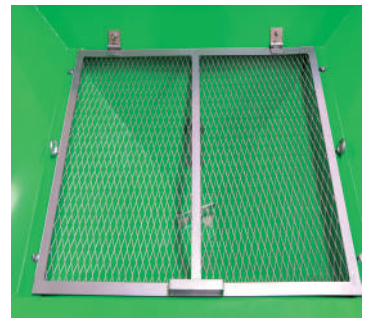

Açılabilir Elek Sistemi
Openable Sieve System

Bereketli toprakların mimarı...

AST
SERIES

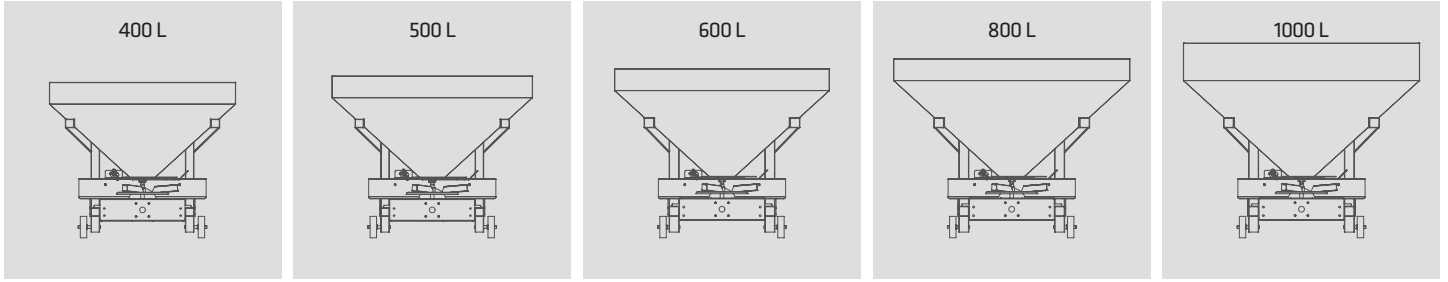
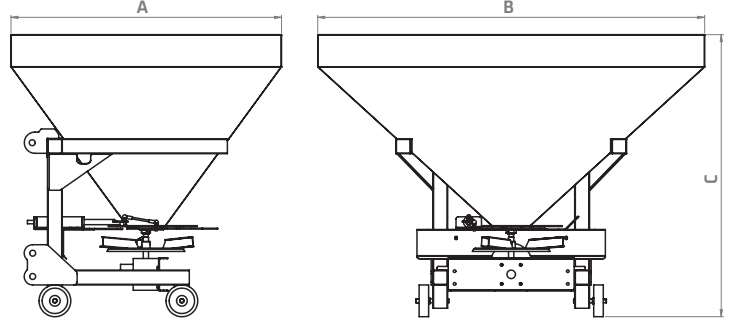

TEKNİK ÖZELLİKLER / TECHNICAL SPECIFICATION

MODEL	AST400	AST500	AST600	AST800	AST1000
Karıştırıcı Tipi / Mixer Type	Dikey / Vertical	Dikey / Vertical	Dikey / Vertical	Dikey / Vertical	Dikey / Vertical
Dağıtıcı Disk Adet / Dispenser Disc Piece	1	1	1	1	1
Her Bir Diskteki Kanat Sayısı / Number of Wings on Each Disc	4	4	4	4	4
Kontrol Tipi / Control Type	Hidrolik / Hydraulic	Hidrolik / Hydraulic	Hidrolik / Hydraulic	Hidrolik / Hydraulic	Hidrolik / Hydraulic
Kuyruk Mili (PTO) Devri (D/dak) / PTO Speed (S/min)	540	540	540	540	540
Çalışma Hızı (km/h) / Operating Speed (km/h)	8-10-12	8-10-12	8-10-12	8-10-12	8-10-12
İş Genişliği (m) / Working Width (m)	16-20	16-20	16-20	16-20	16-20
Gübre Dolum Kapasitesi (lt) / Fertilizer Filling Capacity (lt)	400	500	600	800	1000
Genişlik (A) (mm) / Width (A) (mm)	1037	1070	1102	1152	1152
Uzunluk (B) (mm) / Length (B) (mm)	1303	1403	1503	1653	1653
Yükseklik (C) (mm) / Height (C) (mm)	1085	1130	1180	1250	1375



Çadır / Tent



Krom Disk / Chrome Disc



ASC Serisi | Gübre Serpme Makinesi

Asılı tip ASC Serisi gübre serpme makinelerimiz 3 farklı kapasite (L) seçeneği ile üretilmektedir. Makinemizde bulunan hidrolik kontrol sistemi ile kolay kullanım imkanı sağlanmakta ve gereksiz gübre sarfiyatının da önüne geçilmektedir. 18-24m iş genişliğine sahip disklerimizin üzerinde bulunan açılabilir kanatlarımız, gübrenin tarlaya daha homojen ve akıcı dağılması için gübre cinsine ve istenilen atım mesafesine göre kolay ayarlanabilmektedir. Makinemizde bulunan sürgülü ayar kolları ile sağ veya sol tarafa ayrı ayrı gübre atımı yapılabilmekte ve gübre atış miktarı hassas bir şekilde ayarlanabilmektedir. Depo içerisinde bulunan elek sayesinde yabancı cisimlerin sisteme zarar vermesi önlenmektedir. Gübrenin toz oluşumunu minimum seviyeye indirecek şekilde tasarlanan dikey karıştırıcılar ile gübre akışı kesintisiz olarak sağlanmaktadır. Makinelerimizin yüzey temizliğinde statik boya tekniği öncesi çinko fosfat sistemi uygulanmaktadır. Bu sayede doğal oksitlenmelere karşı metal yüzeylerin ömrü ve mukavemeti artırılmaktadır.

OPSİYONLAR

- Çadır; depodan gübre dökülmesini ve yağışlı havalarda gübrenin ıslanmasını önler.
- Krom disk; gübrenin oluşturabileceği korozyonu önler.



Sürgülü Ayar Kolları
Sliding Adjustment Handles

ASC Series | Fertilizer Spreader

Our hanging type fertilizer spreaders are produced with 3 different capacities (L) options. With the hydraulic control system in our machine, easy use is provided and unnecessary fertilizer consumption is prevented. Angle adjustable wings on our discs, with a working between 18-24m can be easily adjusted according to the type of fertilizer and the desired spreading distance in order to distribute the fertilizer more homogeneously and fluently on the field. With the sliding adjustment handles on our machine, fertilizer can be applied separately to the right or left side and the amount of fertilizer can be adjusted precisely. Thanks to the sieve in the tank, foreign objects are prevented from damaging the system. With the vertical mixer, which is designed to minimize the dust formation of the fertilizer, the fertilizer flow is provided uninterruptedly. Zinc phosphate system is applied before the static paint technique in the surface cleaning of our machines. In this way, the life and strength of metal surfaces against natural oxidation are increased.

OPTIONS:

- Tent; it prevents fertilizer spillage from the tank and wetting of the fertilizer in rainy weather.
- Chrome disc; it prevents the corrosion that can be caused by the fertilizer.

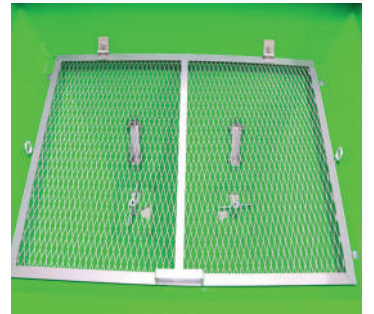

Açılabilir Elek Sistemi
Openable Sieve System

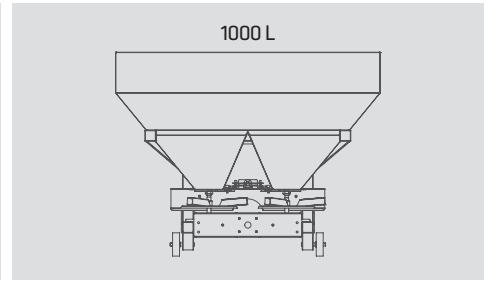
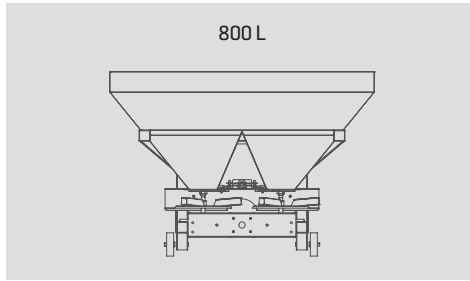
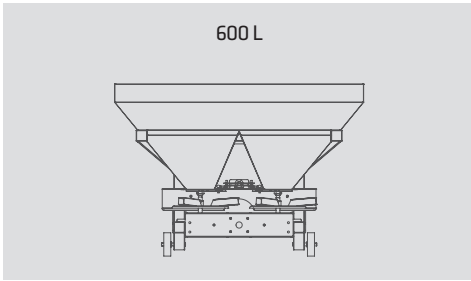
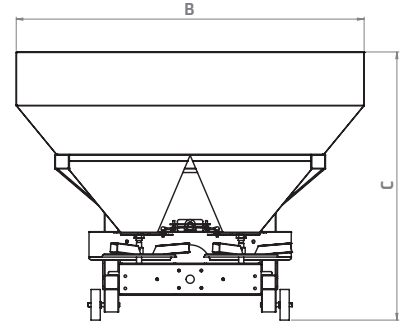
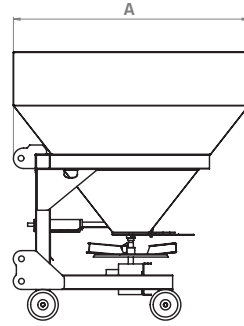

TEKNİK ÖZELLİKLER / TECHNICAL SPECIFICATION

MODEL	ASC600	ASC800	ASC1000
Karıştırıcı Tipi / Mixer Type	Dikey / Vertical	Dikey / Vertical	Dikey / Vertical
Dağıtıcı Disk Adet / Dispenser Disc Piece	2	2	2
Her Bir Diskteki Kanat Sayısı / Number of Wings on Each Disc	3	3	3
Kontrol Tipi / Control Type	Hidrolik / Hydraulic	Hidrolik / Hydraulic	Hidrolik / Hydraulic
Şanzıman Arası Mesafe (cm) / Transmission Distance (cm)	50	50	50
Kuyruk Mili (PTO) Devri (D/dak) / PTO Speed (S/min)	540	540	540
Çalışma Hızı (km/h) / Operating Speed (km/h)	8-10-12	8-10-12	8-10-12
İş Geniřliđi (m) / Working Width (m)	18-24	18-24	18-24
Gübre Dolu Kapasitesi (lt) / Fertilizer Filling Capacity (lt)	600	800	1000
Geniřlik (A) (mm) / Width (A) (mm)	1103	1153	1153
Uzunluk (B) (mm) / Length (B) (mm)	1603	1703	1703
Yükseklik (C) (mm) / Height (C) (mm)	1105	1185	1310



Çadır / Tent



Krom Disk / Chrome Disc



BSC Serisi | Gübre Serpme Makinesi

Asılır tip BSC Serisi gübre serpme makinelerimiz 600L ve 800L kazan tipleri üzerine ilave edilebilen kademelerle 4 farklı kapasitede üretilmektedir. Makinemizde bulunan hidrolik kontrol sistemi ile kolay kullanım imkanı sağlanmakta ve gereksiz gübre sarfiyatının da önüne geçilmektedir. 18-24m iş genişliğine sahip disklerimizin üzerinde bulunan açı ayarlı kanatlarımız, gübrenin tarlaya daha homojen ve akıcı dağılması için gübre cinsine ve istenilen atım mesafesine göre kolay ayarlanabilmektedir. Makinemizde bulunan sürgülü ayar kolları ile sağ veya sol tarafa ayrı ayrı gübre atımı yapılabilmekte ve gübre atış miktarı hassas bir şekilde ayarlanabilmektedir. Kolay kullanım imkanı sunan ve temizlemesi kolay, ergonomik açılır elek sistemi, yabancı cisimlerin sisteme zarar vermesini önlemektedir. Gübrenin toz oluşumunu minimum seviyeye indirecek şekilde tasarlanan dikey karıştırıcılar ile gübre akışı kesintisiz olarak sağlanmaktadır. Makinelerimizin yüzey temizliğinde statik boya tekniği öncesi çinko fosfat sistemi uygulanmaktadır. Bu sayede doğal oksitlenmelere karşı metal yüzeylerin ömrü ve mukavemeti artırılmaktadır. Ayrıca makinemize eklenen çevre koruma bariyeri standart olarak sunulmaktadır.

OPSİYONLAR

- Çadır; çatı tipi çadır sistemi depodan gübre dökülmesini ve yağışlı havalarda gübrenin ıslanmasını önler.
- Krom disk; gübrenin oluşturabileceği korozyonu önler.
- Trafik kiti; güvenli sürüş ve gece çalışma imkanı sağlar.

BSC Series | Fertilizer Spreader

Our hanging type BSC Series fertilizer spreaders are produced in 4 different capacities (L) with steps that can be added on 600L and 800L boiler types. With the hydraulic control system in our machine, easy use is provided and unnecessary fertilizer consumption is prevented. Angle adjustable wings on our discs, with a working between 18-24m can be easily adjusted according to the type of fertilizer and the desired spreading distance in order to distribute the fertilizer more homogeneously and fluently on the field. With the sliding adjustment handles on our machine, fertilizer can be applied separately to the right or left side and the amount of fertilizer can be adjusted precisely. Easy to use and easy to clean, ergonomic opening sieve system prevents foreign objects from damaging the system. With the vertical mixer, which is designed to minimize the dust formation of the fertilizer, the fertilizer flow is provided uninterruptedly. Zinc phosphate system is applied before the static paint technique in the surface cleaning of our machines. In this way, the life and strength of metal surfaces against natural oxidation are increased. In addition, the environmental protection barrier added to our machine is offered as standard.

OPTIONS:

- Tent; roof-type tent system prevents fertilizer from spilling from the warehouse and getting wet in rainy weather.
- Chrome disc; it prevents the corrosion that can be caused by the fertilizer.
- Traffic kit; it provides safe driving and night working opportunity.

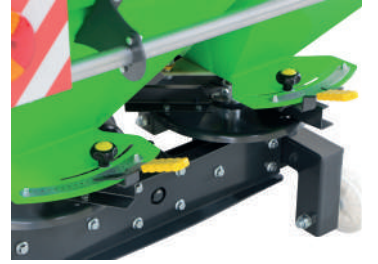

Sürgülü Ayar Kolları
Sliding Adjustment Handles

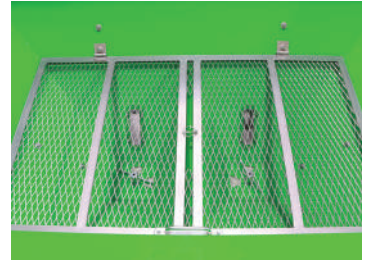

Açılabilir Güçlendirilmiş Elek Sistemi
Openable Reinforced Sieve System



Trafik Kiti Bağlantı Fişi
Traffic Kit Connector Plug

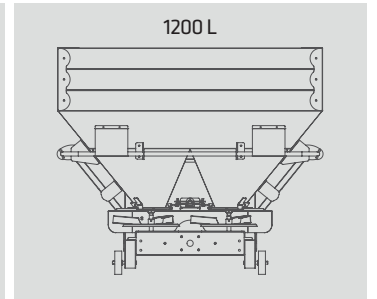
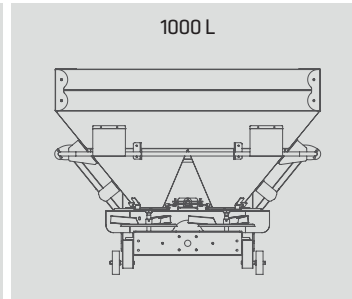
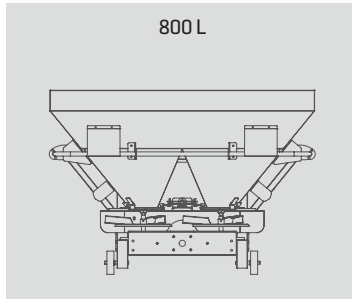
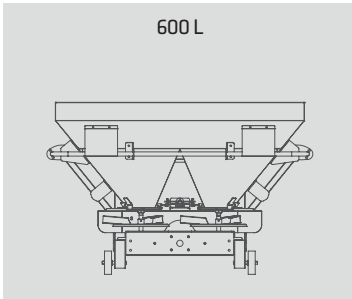
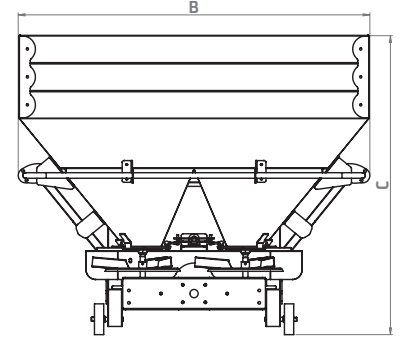
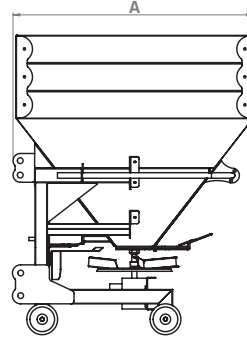

TEKNİK ÖZELLİKLER / TECHNICAL SPECIFICATION

MODEL	BSC600	BSC800	BSC800+200	BSC800+200+200
Karıştırıcı Tipi / Mixer Type	Dikey / Vertical	Dikey / Vertical	Dikey / Vertical	Dikey / Vertical
Dağıtıcı Disk Adet / Dispenser Disc Piece	2	2	2	2
Her Bir Diskteki Kanat Sayısı / Number of Wings on Each Disc	3	3	3	3
Kontrol Tipi / Control Type	Hidrolik / Hydraulic	Hidrolik / Hydraulic	Hidrolik / Hydraulic	Hidrolik / Hydraulic
Şanzıman Arası Mesafe (cm) / Transmission Distance (cm)	50	50	50	50
Kuyruk Mili (PTO) Devri (D/dak) / PTO Speed (S/min)	540	540	540	540
Çalışma Hızı (km/h) / Operating Speed (km/h)	8-10-12	8-10-12	8-10-12	8-10-12
İş Genişliği (m) / Working Width (m)	18-24	18-24	18-24	18-24
Gübre Dolum Kapasitesi (lt) / Fertilizer Filling Capacity (lt)	600	800	1000	1200
Genişlik (A) (mm) / Width (A) (mm)	1118	1170	1170	1170
Uzunluk (B) (mm) / Length (B) (mm)	1712	1712	1712	1712
Yükseklik (C) (mm) / Height (C) (mm)	1105	1185	1320	1455



Çadır / Tent



Krom Disk / Chrome Disc



Trafik Kiti / Traffic Kit



CS Serisi | Gübre Serpme Makinesi

Aşılır tip CS Serisi gübre serpme makinelerimiz 800L kazan tipi üzerine ilave edilebilen kademelerle 3 farklı kapasitede üretilmektedir. Makinemizde bulunan hidrolik kontrol sistemi ile kolay kullanım imkanı sağlanmakta ve gereksiz gübre sarfiyatının da önüne geçilmektedir. Ayrıca CS serisi gübre serpme makinemizde bulunan hidrolik vana sayesinde sağ veya sol tarafa ayrı ayrı gübre atımı yapılabilmektedir. 18-24m iş genişliğine sahip disklerimizin üzerinde bulunan açı ayarlı kanatlarımız, gübrenin tarlaya daha homojen ve akıcı dağılması için gübre cinsine ve istenilen atım mesafesine göre kolay ayarlanabilmektedir. Makinemizde bulunan sürgülü ayar kolları ile gübre atım miktarı hassas bir şekilde ayarlanabilmektedir. Kolay kullanım imkanı sunan ve temizlemesi kolay, ince gözenekli lazer kesim eleklerimiz, yabancı cisimlerin sisteme zarar vermesini önlemektedir. Gübrenin toz oluşumunu minimum seviyeye indirecek şekilde tasarlanan dikey karıştırıcılar ile sekizgen tasarımı sayesinde gübre akışı kesintisiz olarak sağlanmaktadır. Makinelerimizin yüzey temizliğinde statik boya tekniği öncesi çinko fosfat sistemi uygulanmaktadır. Bu sayede doğal oksitlenmelere karşı metal yüzeylerin ömrü ve mukavemeti artırılmaktadır. Ayrıca makinemizin çevresine eklenen çevre koruma bariyeri ve park tekerleri standart olarak sunulmaktadır.

OPSİYONLAR

- Çadır; mekanik kollarla 0-145 derece açılabilen çadır sistemi depodan gübre dökülmesini ve yağışlı havalarda gübrenin ıslanmasını önler.
- Krom disk; gübrenin oluşturabileceği korozyonu önler.
- Trafik kiti; güvenli sürüş ve gece çalışma imkanı sağlar.

CS Series | Fertilizer Spreader

Our hanging type CS Series fertilizer spreaders are produced in 3 different capacities (L) with steps that can be added on 800L boiler types. With the hydraulic control system in our machine, easy use is provided and unnecessary fertilizer consumption is prevented. In addition, thanks to the hydraulic valve in our CS series fertilizer spreader, fertilizer can be spread separately on the right or left sides. Angle adjustable wings on our discs, with a working between 18-24m can be easily adjusted according to the type of fertilizer and the desired spreading distance in order to distribute the fertilizer more homogeneously and fluently on the field. With the sliding adjustment handles on our machine, the amount of fertilizer can be adjusted precisely. Our laser cut sieves with fine pores, which are easy to use and easy to clean, prevent foreign objects from damaging the system. Thanks to the vertical mixers designed to minimize the dust formation of the fertilizer and the octagonal design, the fertilizer flow is provided uninterruptedly. Zinc phosphate system is applied before the static paint technique in the surface cleaning of our machines. In this way, the life and strength of metal surfaces against natural oxidation are increased. In addition, environmental protection barrier and swivel wheels added around our machine are offered as standard.

OPTIONS:

- Tent; the tent system, which can be opened 0-145 degrees with mechanical handles, prevents fertilizer from spilling from the warehouse and wetting the fertilizer in rainy weather.
- Chrome disc; it prevents the corrosion that can be caused by the fertilizer.
- Traffic kit; it provides safe driving and night working opportunity.



Sürgülü Ayar Kolları
Sliding Adjustment Handles

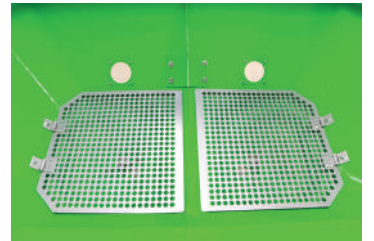

Açılabilir İnce Gözenekli Elek Sistemi
Openable Fine Pores Sieve System



Sağ-Sol Kontrollü Hidrolik Vana
Right-Left Controlled Hydraulic Valve



Mekanik Kollu Açılabilir Çadır
Openable Tent With Mechanical Arm

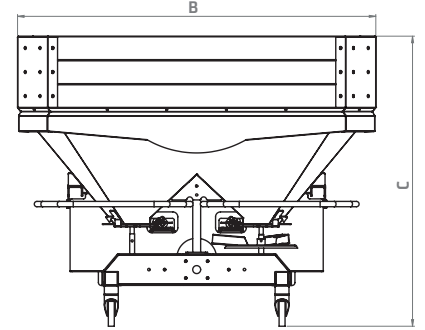
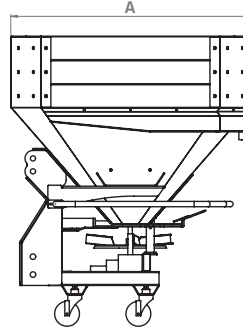

800 L

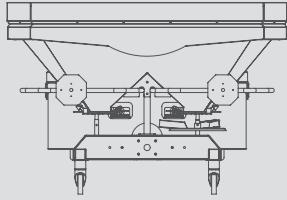

1000 L

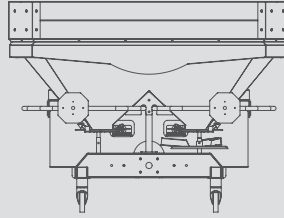

1200 L

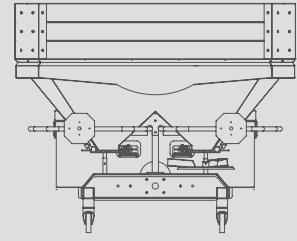

TEKNİK ÖZELLİKLER / TECHNICAL SPECIFICATION

MODEL	CS800	CS800+200	CS800+200+200
Karıştırıcı Tipi / Mixer Type	Dikey / Vertical	Dikey / Vertical	Dikey / Vertical
Dağıtıcı Disk Adet / Dispenser Disc Piece	2	2	2
Her Bir Diskteki Kanat Sayısı / Number of Wings on Each Disc	3	3	3
Kontrol Tipi / Control Type	Hidrolik / Hydraulic	Hidrolik / Hydraulic	Hidrolik / Hydraulic
Şanzıman Arası Mesafe (cm) / Transmission Distance (cm)	65	65	65
Kuyruk Mili (PTO) Devri (D/dak) / PTO Speed (S/min)	540	540	540
Çalışma Hızı (km/h) / Operating Speed (km/h)	8-10-12	8-10-12	8-10-12
İş Genişliği (m) / Working Width (m)	18-24	18-24	18-24
Gübre Dolum Kapasitesi (lt) / Fertilizer Filling Capacity (lt)	800	1000	1200
Genişlik (A) (mm) / Width (A) (mm)	1153	1153	1153
Uzunluk (B) (mm) / Length (B) (mm)	1803	1803	1803
Yükseklik (C) (mm) / Height (C) (mm)	1250	1385	1520



Çadır / Tent



Krom Disk / Chrome Disc

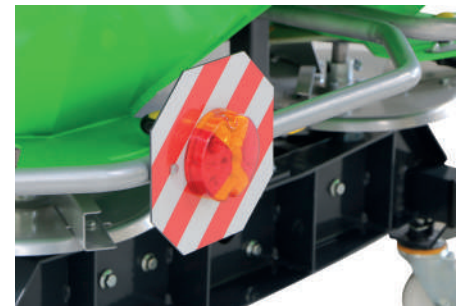

Trafik Kiti / Traffic Kit



DS Serisi | Gübre Serpme Makinesi

Asılı tip DS Serisi gübre serpme makinelerimiz 800L kazan tipi üzerine ilave edilebilen kademelerle 3 farklı kapasitede üretilmektedir. Makinemizde bulunan hidrolik kontrol sistemi ile kolay kullanım imkanı sağlanmakta ve gereksiz gübre sarfiyatının da önüne geçilmektedir. Ayrıca DS serisi gübre serpme makinemizde bulunan hidrolik vana sayesinde sağ veya sol tarafa ayrı ayrı gübre atımı yapılabilmektedir. 24-30m iş genişliğine sahip disklerimizin üzerinde bulunan açı ayarlı kanatlarımız, gübrenin tarlaya daha homojen ve akıcı dağılması için gübre cinsine ve istenilen atım mesafesine göre kolay ayarlanabilmektedir. Makinemizde bulunan sürgülü ayar kolları ile gübre atış miktarı hassas bir şekilde ayarlanabilmektedir. Kolay kullanım imkanı sunan ve temizlemesi kolay, aşırı yüklemelere dayanıklı, piramit şekilli, ince gözenekli lazer kesim eleklerimiz, yabancı cisimlerin sisteme zarar vermesini önlemektedir. Gübrenin toz oluşumunu minimum seviyeye indirecek şekilde tasarlanan dikey karıştırıcılar ile sekizgen tasarımı sayesinde gübre akışı kesintisiz olarak sağlanmaktadır. Makinelerimizin yüzey temizliğinde statik boya tekniği öncesi çinko fosfat sistemi uygulanmaktadır. Bu sayede doğal oksitlenmelere karşı metal yüzeylerin ömrü ve mukavemeti artırılmaktadır. Ayrıca makinemizin çevresine eklenen çevre koruma bariyeri, park tekerleri ve makinenin zemine paralel olarak ayarlanmasında yardımcı olan denge çubukları standart olarak sunulmaktadır.

OPSİYONLAR

- Çadır; mekanik kollarla 0-135 derece açılabilen çadır sistemi depodan gübre dökülmesini ve yağışlı havalarda gübrenin ıslanmasını önler.
- Krom disk; gübrenin oluşturabileceği korozyonu önler.
- Trafik kiti; güvenli sürüş ve gece çalışma imkanı sağlar.

DS Series | Fertilizer Spreader

Our hanging type DS Series fertilizer spreaders are produced in 3 different capacities (L) with steps that can be added on 800L boiler types. With the hydraulic control system in our machine, easy use is provided and unnecessary fertilizer consumption is prevented. In addition, thanks to the hydraulic valve in our DS series fertilizer spreader, fertilizer can be spread separately on the right or left sides. Angle adjustable wings on our discs, with a working between 24-30m can be easily adjusted according to the type of fertilizer and the desired spreading distance in order to distribute the fertilizer more homogeneously and fluently on the field. With the sliding adjustment handles on our machine, the amount of fertilizer can be adjusted precisely. Our pyramid shaped, fine mesh laser cut sieves, which are easy to use and easy to clean, resistant to overloads, prevent foreign objects from damaging the system. Thanks to the vertical mixers designed to minimize the dust formation of the fertilizer and the octagonal design, the fertilizer flow is provided uninterruptedly. Zinc phosphate system is applied before the static paint technique in the surface cleaning of our machines. In this way, the life and strength of metal surfaces against natural oxidation are increased. In addition, environmental protection barrier, swivel wheels and balance bars that help the machine to be used parallel to the ground are offered as standard.

OPTIONS:

- Tent; the tent system, which can be opened 0-135 degrees with mechanical handles, prevents fertilizer from spilling from the warehouse and wetting the fertilizer in rainy weather.
- Chrome disc; it prevents the corrosion that can be caused by the fertilizer.
- Traffic kit; it provides safe driving and night working opportunity.



Sürgülü Ayar Kolları
Sliding Adjustment Handles

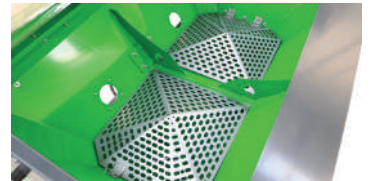

Açılabilir Piramit Şekilli Elek Sistemi
Openable Pyramid Shaped Sieve System



Sağ-Sol Kontrollü Hidrolik Vana
Right-Left Controlled Hydraulic Valve



Mekanik Kollarla Açılabilir Çadır
Openable Tent With Mechanical Arm



Denge Çubuğu
Balance Bar

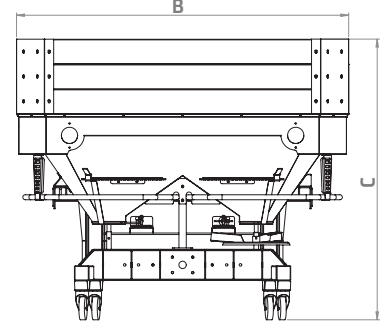
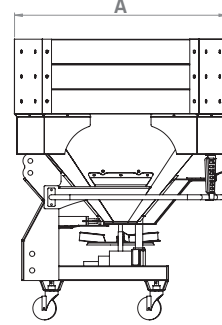

800 L

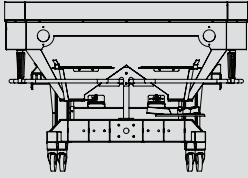

1000 L

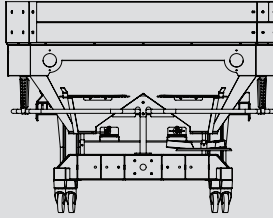

1200 L

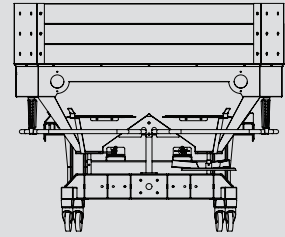

TEKNİK ÖZELLİKLER / TECHNICAL SPECIFICATION

MODEL	DS800	DS800+200	DS800+200+200
Karıştırıcı Tipi / Mixer Type	Dikey / Vertical	Dikey / Vertical	Dikey / Vertical
Dağıtıcı Disk Adet / Dispenser Disc Piece	2	2	2
Her Bir Diskteki Kanat Sayısı / Number of Wings on Each Disc	3	3	3
Kontrol Tipi / Control Type	Hidrolik / Hydraulic	Hidrolik / Hydraulic	Hidrolik / Hydraulic
Şanzıman Arası Mesafe (cm) / Transmission Distance (cm)	80	80	80
Kuyruk Mili (PTO) Devri (D/dak) / PTO Speed (S/min)	540	540	540
Çalışma Hızı (km/h) / Operating Speed (km/h)	8-10-12	8-10-12	8-10-12
İş Geniřliđi (m) / Working Width (m)	24-30	24-30	24-30
Gübre Dolum Kapasitesi (lt) / Fertilizer Filling Capacity (lt)	800	1000	1200
Geniřlik (A) (mm) / Width (A) (mm)	1153	1153	1153
Uzunluk (B) (mm) / Length (B) (mm)	1803	1803	1803
Yükseklik (C) (mm) / Height (C) (mm)	1250	1385	1520



Çadır / Tent



Krom Disk / Chrome Disc



Trafik Kiti / Traffic Kit



*Bereketli
toprakların
mimarı...*



Bereketli toprakların mimarı...





UNOMAS
Tarım Makineleri

Fevzi Çakmak Mh. Arlı Sanayi Sitesi 10776 Sk.
B4 Blok No:5M P.K.42050 Karatay/KONYA

+90 332 502 14 04
+90 332 502 14 05

www.unomas.com.tr
info@unomas.com.tr

 /unomasagro

